



- TASTE THE DIFFERENCE -

## MODEL SL500

This slim line soft serve machine produces the best tasting frozen desserts...smooth, creamy and consistent yogurt, ice cream or sorbet! The 22" wide footprint allows for more units in a smaller space. The SL500 is the perfect yogurt shop freezer and is great for adding flavors to ice cream shops, too! Great for QSRs, retirement villages and hospital cafeterias.

## The Electro Freeze Advantage

- **Innovative Solutions** providing the Best product quality in the industry.
- **Meets ADA Specifications** for self service applications
- **The Finest Frozen Product**, consistently the best frozen product available. Smooth, creamy and profitable
- **Self Closing Spigots** prevents the mess and eliminates waste
- **Adjustable Dispense Rate** set to meet your specific dispensing speed and volume requirements
- **Patented auger** gently blends reducing agitation and maintaining product quality and consistency.
- **Energy Conservation Mode** reduces energy cost and holds product safely during non-business hours
- **Experience Tells** Electro Freeze has been manufacturing quality frozen treat machines since 1929. Superior engineering, product innovations, sturdy construction, quality craftsmanship and dependable performance are Electro Freeze hallmarks.
- **Superior Service Support** backed by a worldwide distributor network.

## GRAVITY SOFT SERVE FREEZER

### Slim Line Series

### 2 Flavor Twist



**SL500 Soft Serve Freezer**

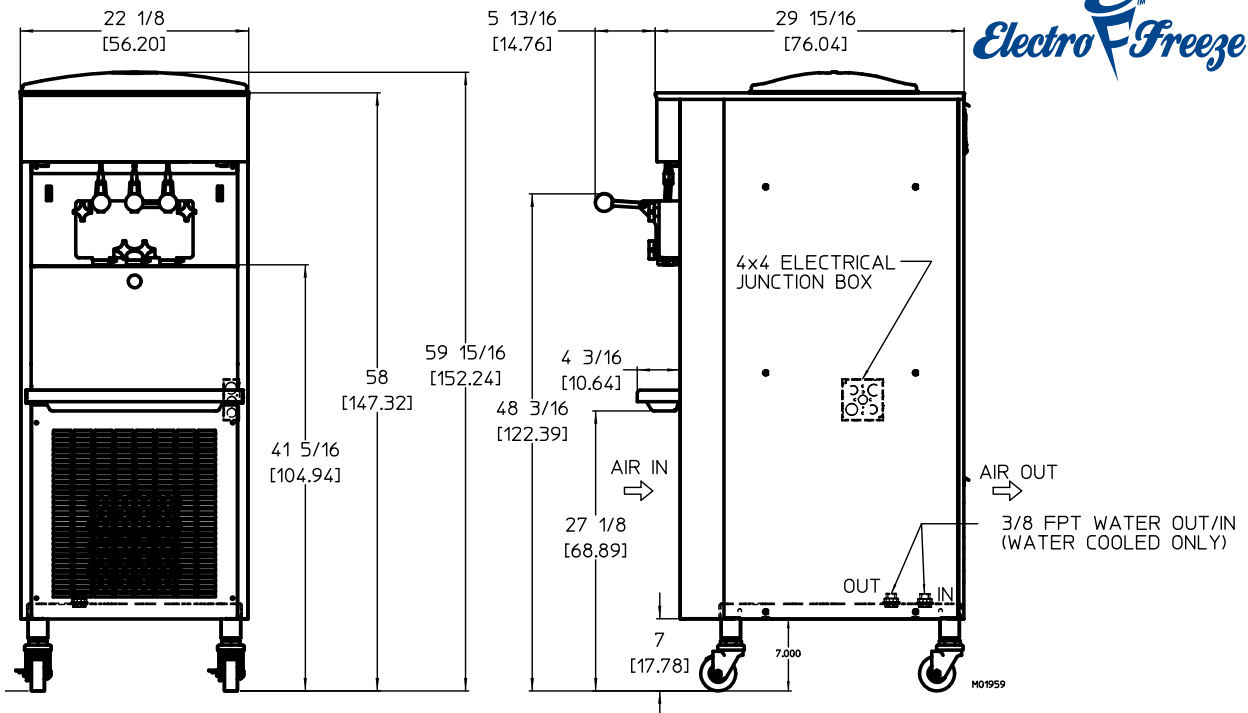

**MODEL SL500 SPECIFICATIONS**

Due to continual product improvements all specifications are subject to change without notice.

<b>Weights</b>	<b>lbs.</b>	<b>kgs.</b>	
Net	550	249	
Crated	671	304	
	<b>cu.ft.</b>	<b>cu.m.</b>	
Volume	58.42	1.65	
<b>Dimensions</b>	<b>in.</b>	<b>cm</b>	
Width	22-1/8	56.20	
Depth	29-15/16	76.04	
Height	59-11/16	151.61	
<b>Electrical</b>	<b>Maximum Fuse Size</b>	<b>Minimum Circuit Ampacity</b>	<b>Poles (P) Wires (W)</b>
208-230/60/1 Air	35	28	2P 2W
208-230/60/1 Water	35	27.5	2P 2W
208-230/60/3 Air	25	20	3P 3W
208-230/60/3 Water	25	20	3P 3W
	<b>Total Amps (Qty)</b>	<b>kW</b>	<b>Poles (P) Wires (W)</b>
230/50/1 Air	29.6		2P 2W
400/50/3 Air	11.8		3P 4W

Electrical characteristics other than above available on request from factory or local distributor. Check nameplate for exact electrical data.

**Bidding Spec**

Electrical: Volt \_\_\_\_\_ Hz \_\_\_\_\_ Ph \_\_\_\_\_  
 Cooling: \_\_\_\_\_ Neutral \_\_\_\_\_ Yes \_\_\_\_\_ No  
 Options: \_\_\_\_\_

**Electrical**

One dedicated electrical connection is required. Manufactured to be permanently connected. See electrical chart for the proper requirement. Consult your local electrical codes for cord and receptacle specifications.

**Beater Motor**

Two, 2 hp.

**Refrigeration Systems**

One, 11,000 Btuh. R404a.  
 Separate Hopper Refrigeration, One, 500 Btuh, R134a.  
 Btuh may vary depending on compressor used.

**Air Cooled**

6" (15.2 cm) air space required on rear panel for proper air circulation and be open on the top.

**Mix Hopper Capacity:** two - 16 quarts (15 liters) each

**Freezing Cylinder Capacity:** two - 3.7 quarts (3.5 liters) each

Certified and/or listed by:



\*UL listed and listed by Underwriters Laboratories under Canadian National Standard C22.2 No. 120-13

\*\*Selected voltages only. Contact H.C. Duke to verify agency needs.



**Electro Freeze div. of H.C. Duke & Son, LLC**

2116-8th Avenue, East Moline, Illinois 61244 USA  
 Phone (309) 755-4553 • (800) 755-4545  
 FAX (309) 755-9858  
 E-mail: sales@electrofreeze.com • www.electrofreeze.com

**Authorized Distributor**